

# PERMIT

**CITY OF NAPOLEON - BUILDING DEPARTMENT**  
**255 West Riverview Avenue, Napoleon, Ohio 43545 - 419-592-4010**

Permit No. 79-79 Issued 7-2-79  
date

Job Location 805 Lynne Ave.  
address

Lot n/a  
sub-div or legal discript

Issued By R.E. Johnson  
building official

Owner Ray Wangrin  
name tel.

Address 805 Lynne Ave.

Agent Lynn Wachtman 599-9863  
builder-eng.-etc. tel.

Address 550 Euclid Ave.

Description of Use New service

Residential one  
no. dwelling units

Commercial \_\_\_\_\_ Industrial \_\_\_\_\_

New \_\_\_\_\_ Add'n. \_\_\_\_\_ Alter \_\_\_\_\_ Remodel XX

Mixed Occupancy \_\_\_\_\_

Change of Occupancy \_\_\_\_\_

Estimated Cost \$ 500.00

FEES	BASE	PLUS	TOTAL
<input checked="" type="checkbox"/> BUILDING			
<input checked="" type="checkbox"/> ELECTRICAL	\$5.00		\$5.00
<input type="checkbox"/> PLUMBING			
<input type="checkbox"/> MECHANICAL			
<input type="checkbox"/> DEMOLITION			
<input type="checkbox"/> ZONING			
<input type="checkbox"/> SIGN			
WATER TAP			
SEWER TAP			
TEMP. ELECT.			
ADDITIONAL PLAN REVIEW	Struct. _____ hrs		
	Elect. _____ hrs		
TOTAL FEES.....			\$5.00
LESS MIN. FEES PAID _____ <small>date</small>			0
BALANCE DUE.....			\$5.00

### ZONING INFORMATION

district	lot dimensions	area	front yd	side yds	rear yd
max hgt	no pkg spaces	no ldg spaces	max cover	petition or appeal req'd	date appr

### WORK INFORMATION:

Size: Length \_\_\_\_\_ Width \_\_\_\_\_ Stories \_\_\_\_\_ Ground Floor Area \_\_\_\_\_

Height \_\_\_\_\_ Building Volume (for demo. permit) \_\_\_\_\_ cu. ft.

Electrical: New 150 amp service  
brief description

Plumbing: \_\_\_\_\_  
brief description

Mechanical: \_\_\_\_\_  
brief description

Sign: \_\_\_\_\_ Dimensions \_\_\_\_\_ Sign Area \_\_\_\_\_  
type

Additional Information: Call for final inspection;

Date 7-5-79 Applicant Signature Lynn B. Wachtman  
owner-agent

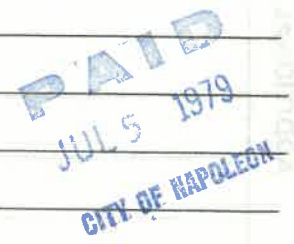



R. E. J.

CITY OF NAPOLEON  
BUILDING INSPECTION DEPARTMENT  
APPLICATION FOR ELECTRICAL PERMIT  
(PLEASE PRINT OR TYPE)

The undersigned hereby makes application for installation or replacement of electrical equipment or service provided, agrees to do all such work in strict accordance with the City of Napoleon's adopted Electrical Code.

Applicant Name Ray Wangrin Address 805 Lynn Ave  
Electrical Contractor Lynn Wachtman Telephone No 599-9863  
Address 550 Euclid

Approved Contractor Telephone No

Address of System 805 Lynn Ave Cost of Project \$500.00

Residential  Commercial  Industrial   
Additional Wiring

Description of Work Replace 60A. Service with new 150 A. service

Estimated Cost of Work 150A of the Capacity 00

Is this work to be done in a public building? No

NEC REQUIREMENT: GROUND-Fault INTERRUPTER PROTECTION IS REQUIRED IN ALL 120V AC, 15 AMP, CIRCUITS WHICH ARE PART OF A COMPLETE ELECTRICAL SERVICE AND ALSO ON BATHROOM, OUTDOOR, AND GARAGE RECEPTACLES IN ALL DWELLING UNITS.

REGISTRATION FOR PERMIT SHALL BE OBTAINED BY THE APPLICANT AT THE CITY CLERK'S OFFICE, 100 N. MAIN ST., NAPOLEON, OHIO 44662. FEE: \$10.00 PER PERMIT.

6-28-79

Lynn R. Wachtman

PERMIT NO. 79-79

PROJECT COST \$500



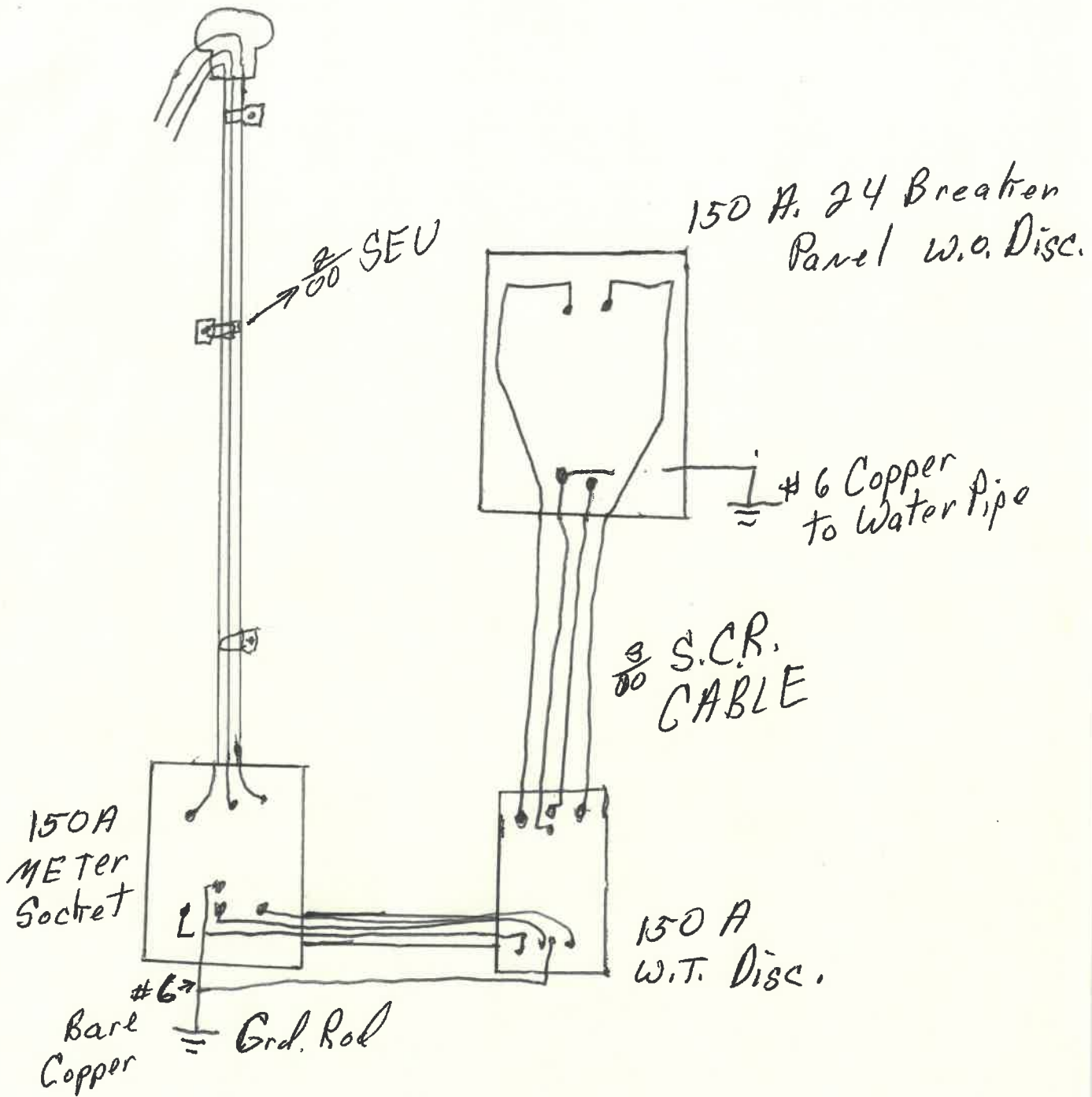

Contractor - Lynn Wachtman  
 Home Owner - Ray Wangrin  
 Address - 805 Lynn Ave.





CITY OF NAPOLEON

Engineering Department

ELECTRICAL INSPECTION FIELD REPORT

255 Riverview Avenue Napoleon, Ohio 43545  
(Please Print or Type)

Date 7-7-79

Permit No. 79-79

Type of Inspection SERVICE

Type of Occupancy SINGLE FAM.

Project Name RAY WACHTMAN

Address 805 LYNNIE AVE.

City NAP State OH.

Approved [checkmark]

Violation

Electrical Contractor LYNN WACHTMAN

Remarks:

Code Reference

Service only (outdoor) no entry.  
Sticker on bottom of meter base.

Compliance Time

Inspectors Signature [Signature]

Copies To:

White - Applicant Yellow - Engineering Pink - Electrical Inspector

